

ROSS Laboratory High Shear Mixer HSM-100LCI-T Specifications and Dimensions

STANDARD FEATURES:

- 1 HP drive, 115 volt, 50/60 Hz, single phase, 20 amp motor.
- Mixer and controls are wired and include a cord and plug.
- IP55/NEMA 12 motor.
- Variable speed control from 500 -10,000 rpm (+/- 1% speed accuracy).
- Color touch screen control and display including RPM, percent of load, speed batch timer and temperature calibration (up to 300°F or 150°C).
- Electronic pushbutton lift.
- Stainless steel type 316 wetted parts.
- Sturdy frame for bench mounting.
- Non-stainless steel external parts coated with a two-part acrylic urethane enamel coating.
- Easy to disassemble and clean.

AVAILABLE OPTIONS:

- Additional shaft mounted propellers.
- Variety of rotor shaft bushing materials.
- Temperature probe with beaker clip. Temperature is displayed on the digital readout.
- Vessel/Beaker clamp attachment.
- Optional voltages: 190 - 230 V, 50/60 Hz.
- Hastelloy product contact surfaces.

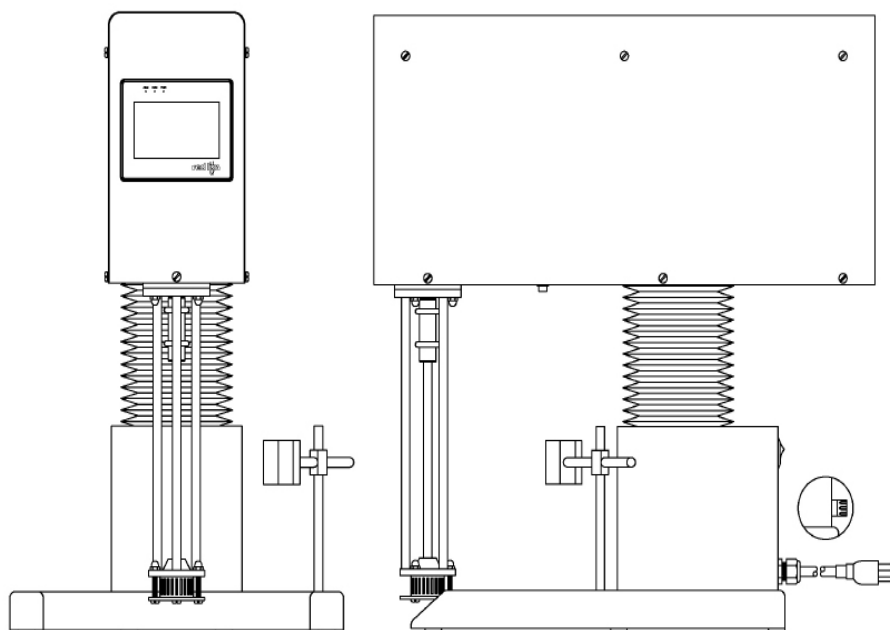

AVAILABLE MIXING ATTACHMENTS:

- HSM Attachment: High Shear Rotor/Stator attachment complete with disintegrating, slotted, and fine screen stator heads. Attachment is equipped with TEFLON® bushing.
- Inline HSM Attachment: Inline attachment complete with disintegrating, slotted, quad and fine screen stator heads.
- HSD Attachment: High Speed Disperser and propeller mixer attachment.
- Micro HSM Attachment: High Shear Micro Rotor/Stator attachment for batches between 50 mL and 500 mL.

Model	Speed RPM	Overall Raised Height*		Overall Lowered Height*		Overall Width*		Overall Length*		Distance Between Feet*		Water Capacity		Weight	
		in	mm	in	mm	in	mm	in	mm	in	mm	gal	ℓ	lbs	kg
100LCI-T	500 - 10,000	39.4	1000	24.5	622	15	381	22.6	575	12	305	0.3 - 4	1.1-15	62	28

*Dimensions shown are approximate and subject to change without notice due to design improvements, selected options, or supplier component substitutions.



CHARLES ROSS & SON COMPANY

P.O. Box 12308

710 Old Willets Path, Hauppauge, NY 11788

631-234-0500 Fax: 631-234-0691

www.mixers.com

sales@mixers.com

Model HSM-100LCI-T Attachments

High Shear Mixer (HSM)

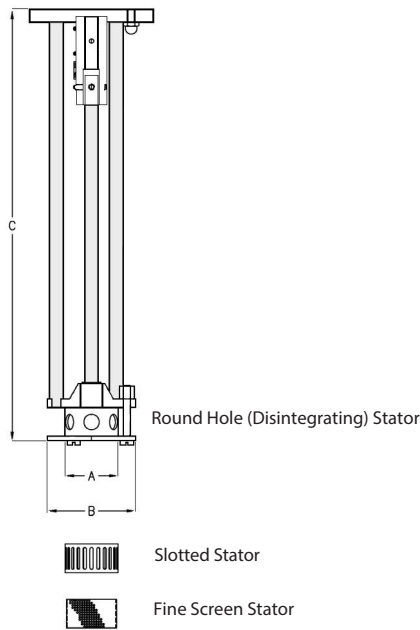

High Speed Dispenser (HSD)

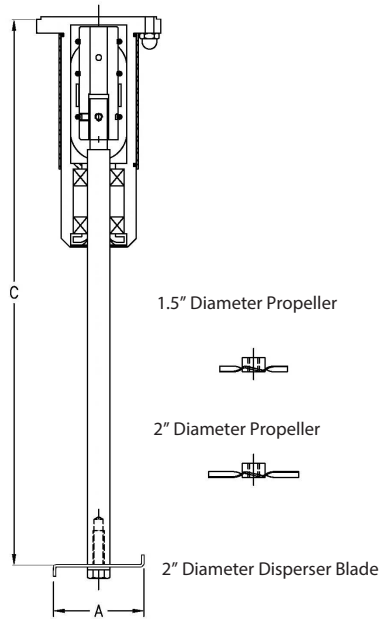

Micro High Shear Mixer (Micro HSM)

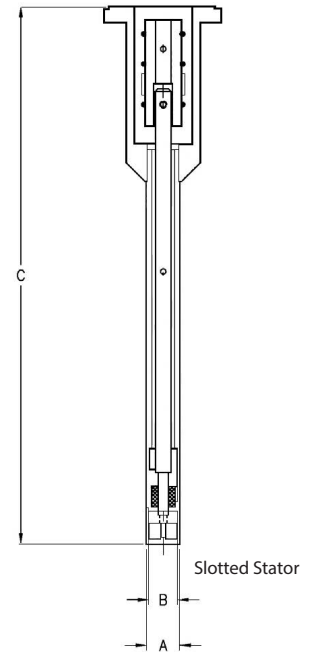

Inline Quad High Shear Mixer (Quad HSM)

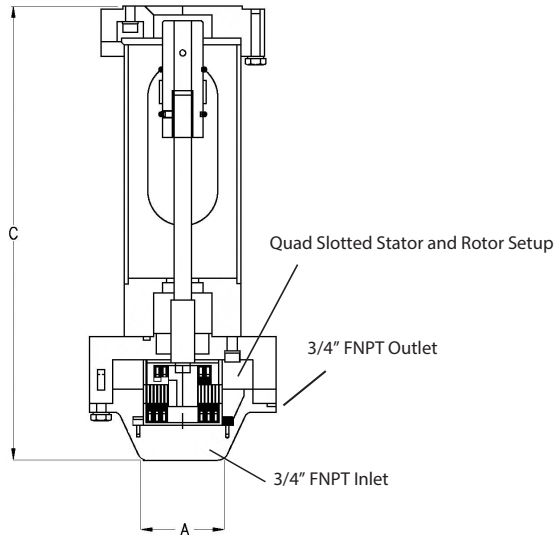

Inline High Shear Mixer (Inline HSM)

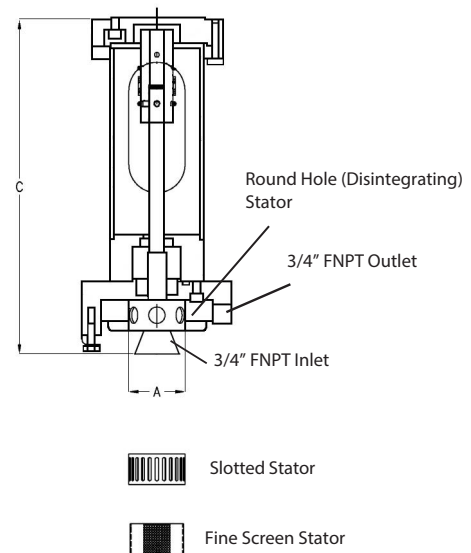

Attachment	Rotor Diameter (A)		Lower Flange Diameter (B)		Shaft Length (C)	
	in	mm	in	mm	in	mm
HSM	1.4	34.9	2.5	63.5	12.3	312.7
HSD	2.0	50.8	N/A	N/A	12.1	306.4
Micro HSM	0.7	17.5	0.8	20	13.6	346.1
Quad HSM	1.4	34.9	N/A	N/A	9.9	251
Inline HSM	1.4	34.9	N/A	N/A	9.19	233



CHARLES ROSS & SON COMPANY
 P.O. Box 12308
 710 Old Willets Path, Hauppauge, NY 11788
 631-234-0500 Fax: 631-234-0691
 www.mixers.com
 sales@mixers.com

*Dimensions shown are approximate and subject to change without notice due to design improvements, selected options, or supplier component substitutions.